



OPTICAL MINIATURE SENSORS

 di-soric

OVERVIEW

FIELDS AND INDUSTRIES FOR USE

High-performance miniature sensors are your first choice when minimal installation space is available in automation technology. Optical miniature sensors are suited for location detection as well as the precise detection of the positions of quickly moving objects. The presence of small objects at defined locations or in an area can thereby be reliably detected.

Location

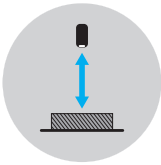

- Continuous presence control
- The detection of an object often occurs in the center of the object
- Objects are large and mostly flat

Typical application:
Location control in a robotic gripper

Position

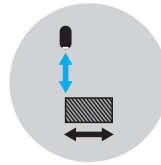

- Checking the position of an object
- The detection of an object often occurs on the edge of the object
- Detection of mostly moving objects

Typical application:
Material flow control

Presence

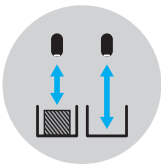

- Check whether a feature is present
- Frequently checked features: Distance, darkness or brightness

Typical application: Assembly control

Area detection

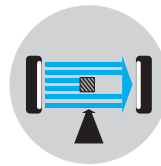

- Detection of small, moving objects
- The position of the object varies greatly
- Objects are detected within a range

Typical application: Counting processes

Optical miniature sensors for the most diverse applications in various industries

Assembly and handling technology

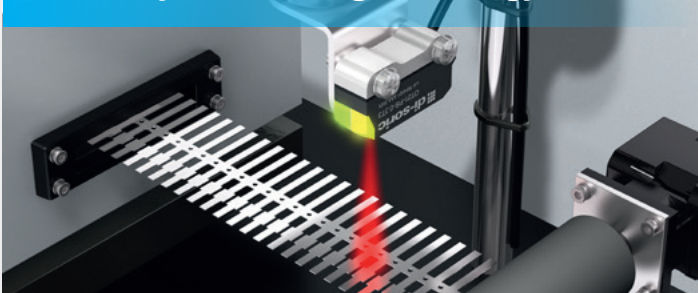

Packaging technology

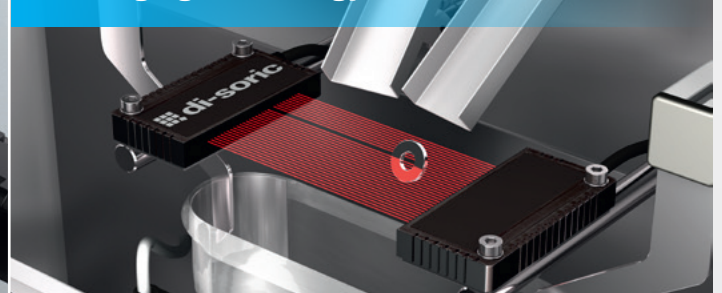

Robotics

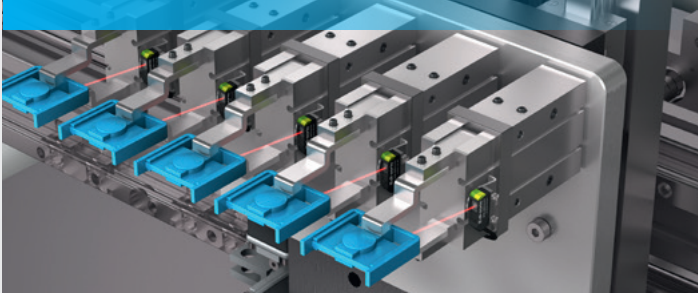

Laboratory automation

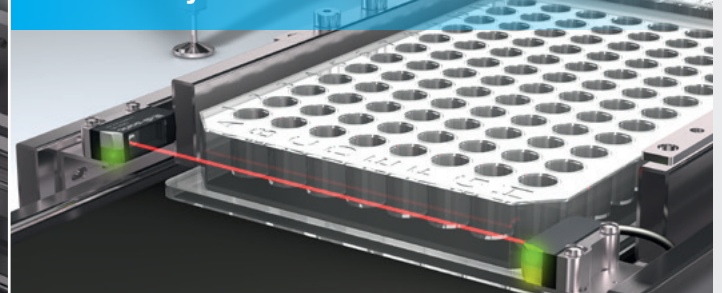

OPTICAL MINIATURE SENSOR SERIES

O-21 MINIATURE, O-D4 / O-M5 AND PLASTIC FIBER-OPTIC SENSORS

Series O-21 diffuse reflective sensors and light barriers are very small, high-performance, and they can be easily integrated and digitally connected with IO-Link. The cylindrical and threaded designs in series O-D4 or O-M5 are distinguished by their minimal diameter. With the modular KL plastic fiber-optics and the high-performance OLV-K Amplifier, demanding applications can be implemented in narrow spaces.

O-21 Miniature

- Diffuse reflective sensors and light barriers available with 4 functional principles
- High-performance series with red light LED
- Functionally reliable object detection due to optimized optics
- Robust construction with metal fastening element
- IO-Link with pnp switch output



O-D4 / O-M5

- Diffuse reflective sensors in a small format
- Ready-to-install with preset scanning ranges
- No operating elements, tamper-proof
- Stainless steel housing, ideal for strict hygiene and cleanliness requirements

OLV-K Amplifier

- Amplifier for plastic fiber-optics for top-hat rail assembly
- High-performance: long ranges, fast
- For demanding applications with high functional reliability
- Comfortable and easy to use
- Two digital LED displays for the switching point and actual value



KL plastic fiber-optics

- Modular, comprehensive fiber optics program
- Miniaturized for detection of small parts in narrow spaces
- Variants with 90° beam deflection for use in tight spaces
- Robust and durable with kink protection and stainless steel probe



DIFFUSE REFLECTIVE SENSORS AND LIGHT BARRIERS O-21 MINIATURE

4 functional principles, can be easily integrated, can be used flexibly

The very small, high-performance diffuse reflective sensors and light barriers in the O-21 miniature series can be integrated in a space-saving manner. The background suppression sensors are suited for detecting small and flat objects. All O-21 miniature sensors distinguish themselves with their space-saving design and large ranges. The variants with pnp switching output have an IO-Link interface.



OH21 Background suppression sensors

- Preset scanning ranges 15 mm, 50 mm, 80 mm
- Adjustment of scanning range in mm-grid via IO-Link
- > For the detection of minimal height differences

OT21 Diffuse reflective sensors

- Scanning object detection up to 180 mm
- Diagnosis of functional reliability with status LED
- > Efficient detection of light objects without background

OR21 Retro reflective sensors

- High functional reliability through a large range
- Small light spot makes small reflectors possible
- > Large ranges with little assembly effort



OE21 Through-beam sensors

- High functional reliability through a large range
- Diagnosis of functional reliability with status LED
- > Large ranges with little assembly effort

O-21	OH21 Background suppression sensors	OT21 Diffuse reflective sensors	OR21 Reflective light barrier	OS21/OE21 Through-beam sensor (transmitter and receiver)
Dimensions	(H x W x D) 28.1 x 8.1 x 14.4 mm			
Scanning range max.	15 / 50 / 80 mm ¹	180 mm		
Range max.			1 800 mm ²	3 000 mm
Switching output	pnp, 100 mA, NO/NC, can be configured via IO-Link or npn, 100 mA, NO			
Switching frequency	1 000 Hz			
Connection	Cable 2.0 m, 3-pin or Cable 0.3 m/Plug M8, 3-pin			

¹ Scanning ranges preset to 15 / 50 / 80 mm, with pnp switching output can be configured via IO-Link | ² with reflector R19x54

O-21 MINIATURE WITH IO-LINK

O-21 miniature sensors and IO-Link advantages

IO-Link is a worldwide communication standard according to IEC 61131-9. Sensors and actuators with an immense range of functions and capabilities become intelligent and active process devices in the field with IO-Link. Production processes thereby become more flexible, more transparent, more efficient and more cost-efficient. IO-Link transforms sensors into digital products and enables Industry 4.0 system designs.

1 Ready for digitization



Digitize your systems with IO-Link. IO-Link supports the identification, configuration and diagnosis of O-21 series sensors, and this makes the remote maintenance of systems possible right into the device. With parameter memory in the IO-Link Master, sensors can easily be exchanged and commissioned with identical settings.

2 Configuration instead of specific hardware



The compact sensors in the O-21 miniature series can be conveniently adjusted via the control without manual operation using IO-Link. Using a configuration coordinated with the application case, the productivity of sensors in machines and systems can be optimized without additional hardware expense.

3 Preventive maintenance through diagnosis



Series O-21 miniature sensors detect functional reserve or distance from the object in mm via IO-Link. If the objects or ambient conditions change, an assessment of the sensor function is possible. Diagnosis enables optimized commissioning, coordinated service cycles and the use of remote maintenance.

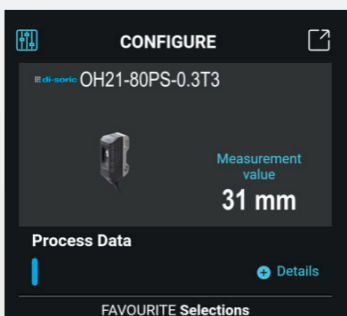

Configuration and diagnosis via IO-Link

OH21 with CMOS line and measuring function via IO-Link

The adjustment of scanning range is possible in the mm-grid. The sensor is thereby ideally suited for the detection of minimal differences in height.

Screenshot IOL Portable: Configuration OH21

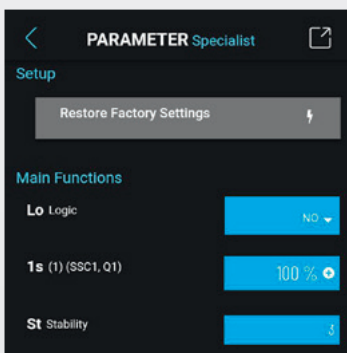

OR21, OT21 and OE21 with diagnosis of functional reliability

The adjustment of the switching point is done using the 1% grid. The diagnostic value "Stability" signals functional reliability.



IOL PORTABLE
Handheld

Screenshot IOL Portable: Configuration OR21

APPLICATION EXAMPLES

O-21 MINIATURE

Robotics

Discharging an injection molding machine

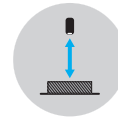
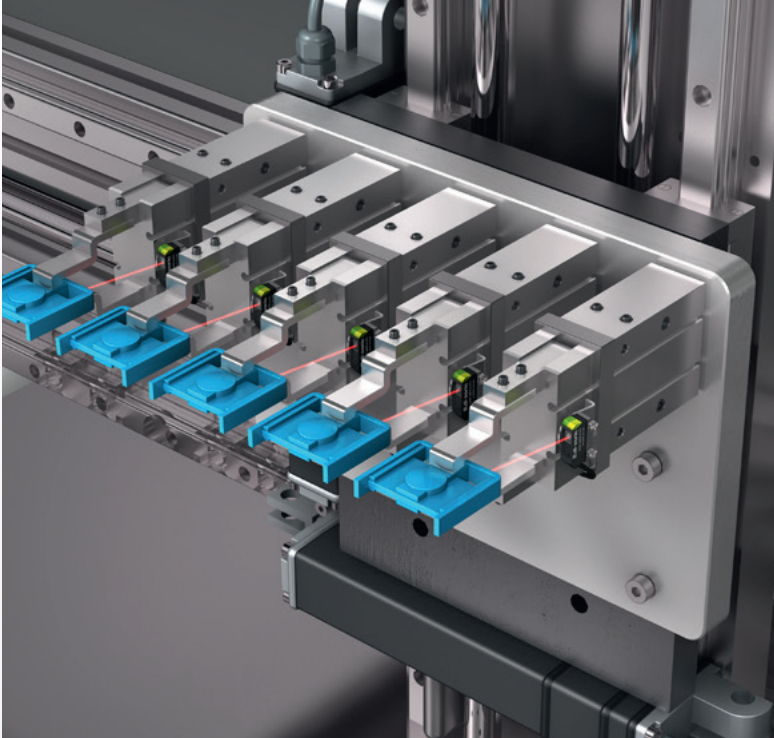

Location

A line robot with pneumatic grippers removes parts from an injection mold. Several OH21 sensors check the location of the injection molded parts in the grippers. The miniature design makes space-saving mechanical integration possible. With the high-performance background suppression, the location of dark parts can be precisely determined.

Background suppression sensor
OH21-80PS-0.3T3



Packaging technology

Triggering a labeling machine

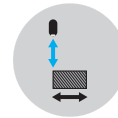
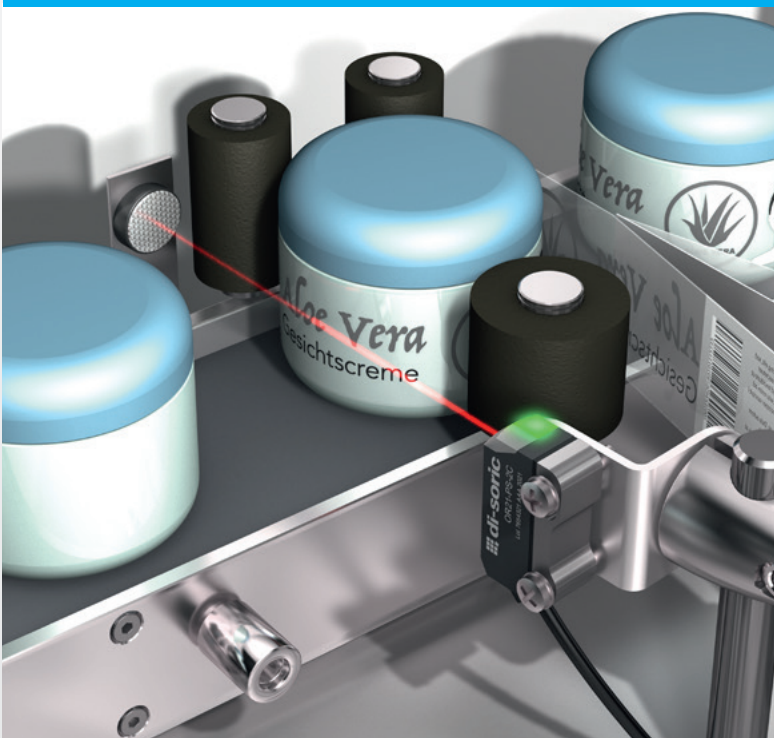

Position

In labeling machines, sensors detect containers to be labeled. It is decisive that the containers are detected in a precise and timely manner.

The OR21 miniature retro reflective sensor can be operated with very small reflectors. Functionally reliable, space-saving triggering can thereby be realized in the narrow installation space of the label dispenser.

Retro reflective sensor
OR21-PS-2C,
Reflector **R 21 M3**



Assembly and handling technology

Monitoring of belt feeding

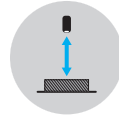
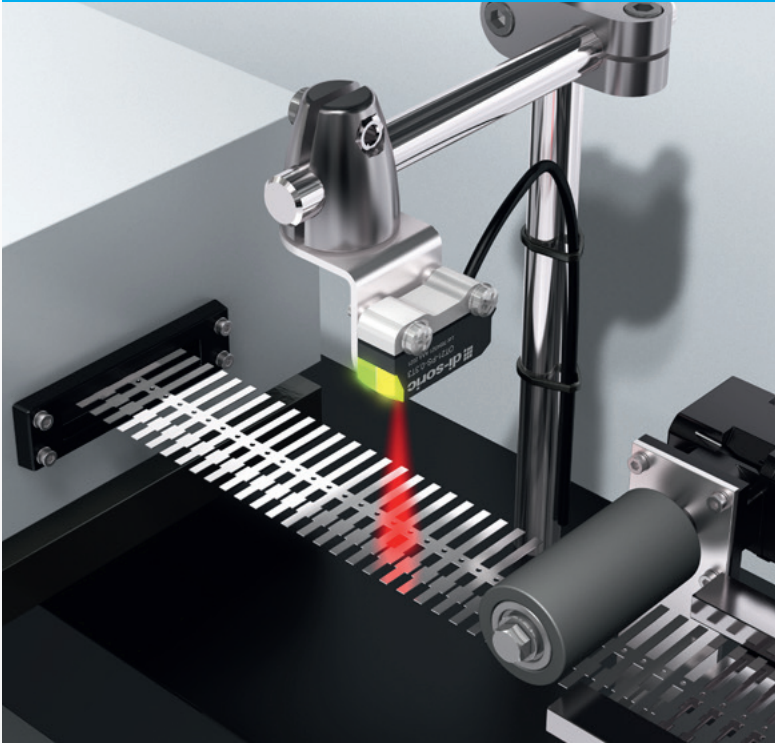

Location

Punched electrical contacts are belt-fed as material in an assembly machine. To monitor the flow of material, the open belt material must be detected in a functionally reliable manner. The OT21 retroreflective diffuse sensor has a large light spot which suppresses holes and breaks.

Diffuse reflective sensor
OT21-PS-0.3T3



Laboratory automation

Position control of laboratory vessels

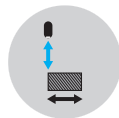
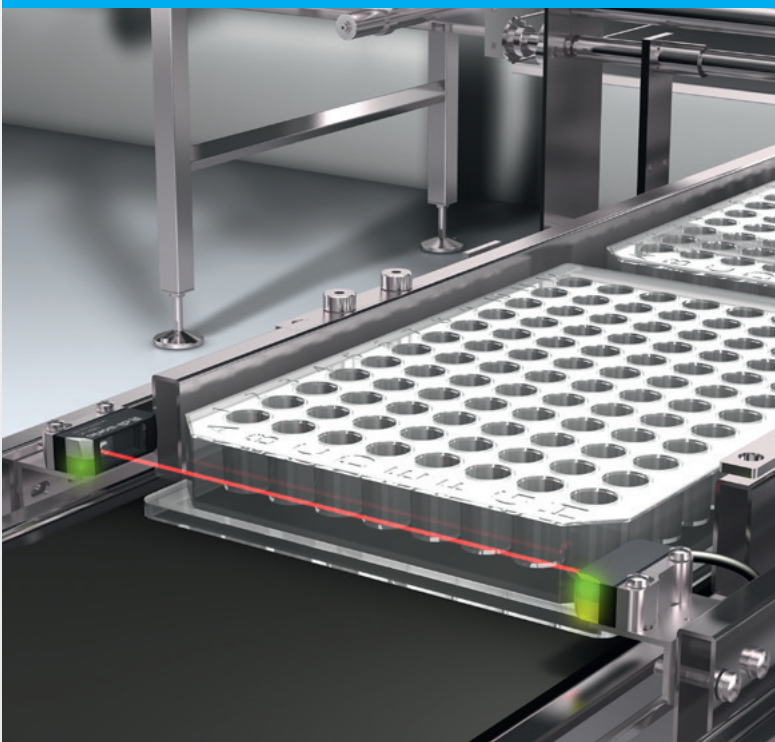

Position

At a precise handover point, sample vessels must be positioned precisely. The OS21 and OE21 miniature through-beam sensors can be integrated in the guide rail in a space-saving manner. Large status LEDs and IO-Link make the continuous monitoring of the sensor function possible.

Through-beam sensor
transmitter receiver
OS21-2C OE21-PS-2C



DIFFUSE REFLECTIVE SENSORS

SERIES O-D4 AND O-M5

THE SMALLEST CYLINDRICAL DIFFUSE REFLECTIVE SENSOR – HIGHLY RELIABLE AND ROBUST WITH THE MOST MINIMAL SPACE REQUIREMENTS

The extremely narrow, cylindrical diffuse reflective sensors are the ideal solution in narrow installation situations in compact machines. Sensors in the O-M5 series can be integrated into machine parts with an M5 thread, and sensors in the O-D4 series can be integrated into machine parts perfectly with clamps. The robust stainless steel design, preset scanning ranges and the easily visible red light LED make quick commissioning and operation under difficult conditions possible.

O-D4

- Energetic scanner in a very small, cylindrical design with a 4 mm diameter
- Functionally reliable object detection through matching optics and red light LED
- Fixed scanning ranges: 10, 20, 50 mm
- For fast processes: Switching frequency 1000 Hz
- Operation in a large temperature range: -25 °C to + 65 °C
- Stainless steel housing



O-M5

- Energetic scanner in very small M5 threaded design
- Functionally reliable object detection through matching optics and red light LED
- Fixed scanning ranges: 10, 20, 50 mm
- For fast processes: Switching frequency 1000 Hz
- Operation in a large temperature range: -25 °C to + 65 °C
- Stainless steel housing



O-D4	OTD04-10PS-2R	OTD04-20PS-2R	OTD04-50PS-2R	OTD04-10PS-T3	OTD04-20PS-T3	OTD04-50PS-T3
O-M5	OTM05-10PS-2R	OTM05-20PS-2R	OTM05-50PS-2R	OTM05-10PS-T3	OTM05-20PS-T3	OTM05-50PS-T3
Scanning range	10 mm	20 mm	50 mm	10 mm	20 mm	50 mm
Connection	Cable 2.0 m, 3-pin			M8 connector, 3-pin		

APPLICATION EXAMPLES

O-D4 OR O-M5

Robotics

Object detection in gripper

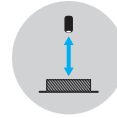
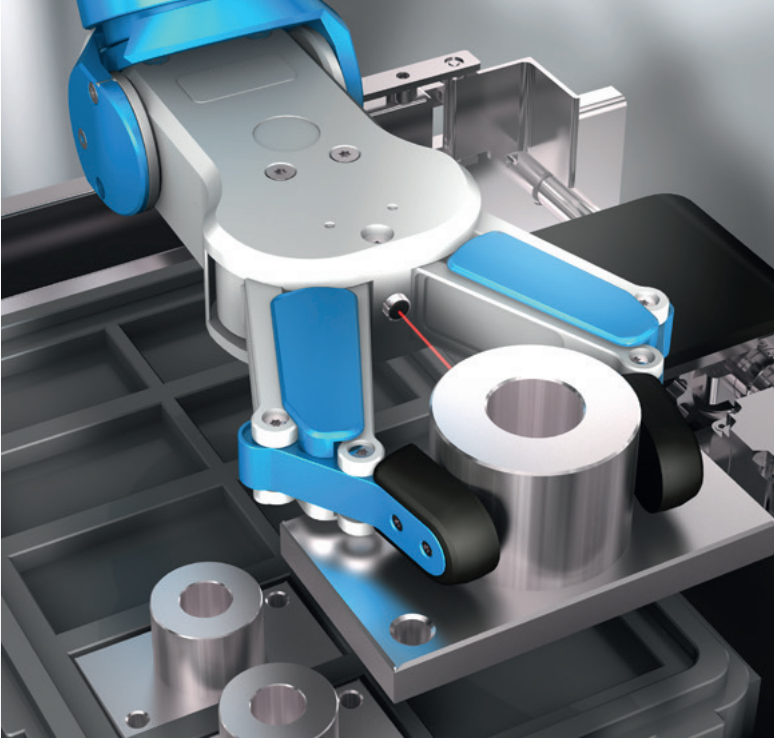

Location

During gripping, workpieces must be located in the gripper. The O-M5 series diffuse reflective sensors with a stainless steel housing can be integrated in a space-saving manner directly in the gripper. Matching optics and red light LED with a narrow beam angle make scanning ranges of up to 50 mm possible.

Retroreflective
diffuse sensor
OTM05-50PS-2R



Laboratory automation

Checking the presence of film on a sample vessel

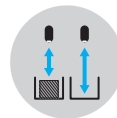

Presence

Before the robot grips a sample vessel, it is checked during the feeding process whether a sealing film is present. The series O-D4 diffuse reflective sensor detects the film due to reflectivity. Due to the smooth stainless steel housing, the sensor is suited for process steps with high hygiene and cleanliness requirements.

Retroreflective
diffuse sensor
OTD04-20PS-2R



PLASTIC FIBER-OPTIC SENSORS

OLV-K AMPLIFIER

HIGH PERFORMANCE, MODULAR, EASY TO OPERATE AND LOW SPACE REQUIREMENTS

The OLV 71 amplifier is fast, the high transmission power makes large ranges possible with high functional reliability. Operation is easy and is done with four buttons. Two LED displays for switching point and actual value facilitate commissioning. With the right fiber-optics, applications can be handled with the lowest space requirements.

Fiber-optic amplifier OLV 71

- Amplifier for plastic fiber-optic cables 2 x 2.2 mm
- High range, up to 4000 mm with a one-way fiber-optic cable and attachment optics
- For fast processes: Minimal response time 0.25 ms
- Two digital LED displays for the switching point and actual value
- Simple, intuitive 4-button operation
- Light/dark switching configurable
- Time functions and offset function can be configured



Intuitive operation and high performance ensure maximum control and efficiency

Switching point Digital display in green

Actual value Digital display in red

Connection

M8 plug or connection cable

+ / - buttons

Manual fine tuning of the switching point, configuration in setting mode

Switching output display

Yellow status LED

SET button > Activation of menu

Assembly on top-hat rail

TEACH button > Navigation in setting mode



OLV-K	OLK 71 P3-T4	OLK 71 N3-T4	OLK 71 P3-3	OLK 71 N3-3
Switching output	pnp, NO/NC ¹	nnp, NO/NC ¹	pnp, NO/NC ¹	nnp, NO/NC ¹
Connection	M8 connector, 4-pin		Cable 2 m	

¹ Can be configured with buttons, display

PLASTIC FIBER-OPTIC SENSORS

KL PLASTIC FIBER OPTICS

AS KLT DIFFUSE REFLECTIVE SENSORS OR KLE THROUGH-BEAM SENSORS. ROBUST, DURABLE AND CUSTOMIZABLE LENGTH.

di-soric offers a wide range of fiber optic products with accessories. The portfolio includes, among others, sensor probes made of stainless steel with kink protection, sensor probes with light bands for range monitoring and fiber optics for the detection of the smallest parts.

KLT fiber optics

Functional principle:
Retroreflective diffuse sensor

- Transmitter and receiver fibers in one housing
- Objects are recognized through reflection

Advantages:

- Minimal space requirement
- Minimal assembly effort

Fiber-optic variants:

- Coaxial fibers for precise detection
- Focus optics and narrow beam to increase scanning range
- Straight threaded design, or 90° deflection
- Bendable, smooth sleeve design
- Light band design for range detection
- V-optic design with background suppression

KLE fiber optics

Functional principle:
Through-beam sensor

- Transmitter and receiver fibers in two separate housings
- Objects are detected through interruption of the light beam

Advantages:

- For precise position control
- Large range

Fiber-optic variants:

- Small fiber diameter for precise positioning
- 400 % more range with attachment lens for threaded design
- Straight threaded design, or 90° deflection
- Smooth sleeve design with 90° deflection
- Light band design for range detection
- Flat design for space-saving installation

You can find the optimal plastic fiber-optics for your application with our selector at www.di-soric.com:

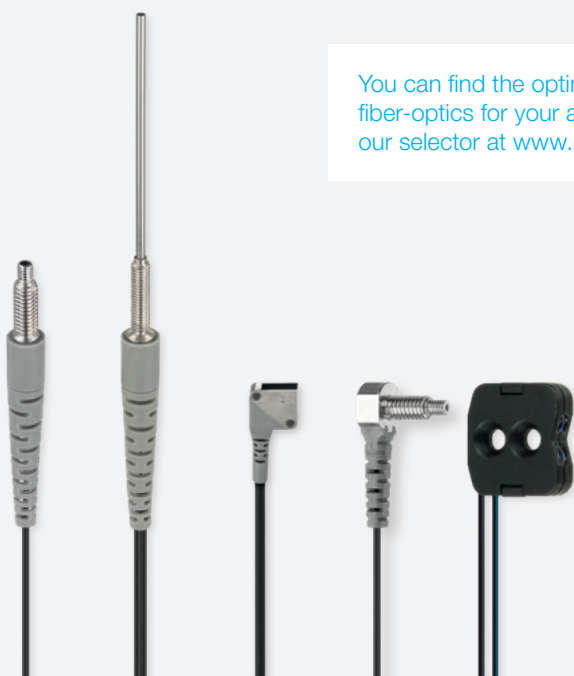

PLASTIC FIBER-OPTIC SENSORS

APPLICATION EXAMPLES

Packaging technology

Container accumulation monitoring

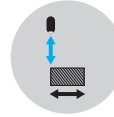
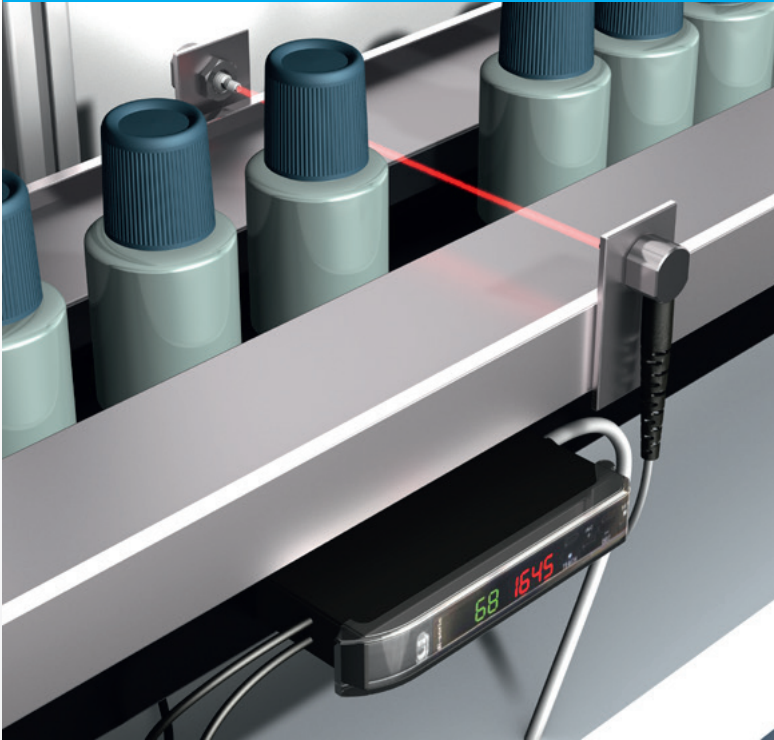

Position

The material flow is monitored during feeding. If containers become congested, the OLK 71 amplifier switches and the feed is stopped. Robust fiber-optics with a radial scanning head with 90° deflection and flexible assembly position of the amplifier make space-saving solutions possible.

Fiber-optic amplifier
OLK 71
Plastic fiber-optic
KLER-M4-T2-1



Robotics

Positioning in guide rail

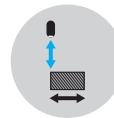

Position

An object that is fed must be positioned precisely for a gripper, which is why a miniaturized fiber-optic cable is used. With the flat design and recessed fastening screws, space-saving installation is possible.

Fiber-optic amplifier
OLK 71
Plastic fiber-optic
KLE-Q10M-1-0.5



FIBER-OPTIC AMPLIFIER OLK-71 WITH KL PLASTIC FIBER OPTICS

Packaging technology

Counting parts in a tubular bag machine



Range detection

Several small parts are packaged in a tubular bag packaging machine. Checking the number of parts is done with a fiber-optic cable with a light band. Falling parts from 1 mm can thereby be detected in the entire detection range of the fiber-optic cable.

Fiber-optic amplifier
OLK 71
Plastic fiber-optic
KLEMR-Q38K-1-24



Assembly and handling technology

Checking the presence of a thread

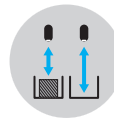
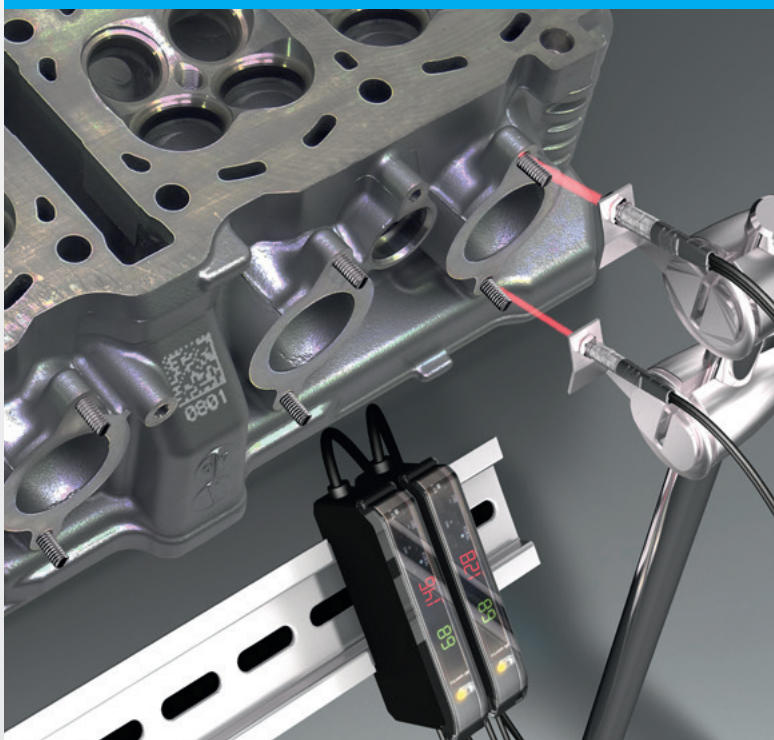

Presence

The presence of an external thread on a pre-assembled bolt is to be checked. Fiber optics positioned at an angle with a narrow light beam enable detection at a working distance of up to 20 mm. Adjustment works by simple teach-in at the OLK 71.

Fiber-optic amplifier
OLK 71
Plastic fiber-optic
KLT-M6-T2-1.5NB



OPTICAL MINIATURE SENSORS ACCESSORIES

KL ACCESSORIES PLASTIC FIBER-OPTICS

Attachment optics for range increases with through-beam sensors

- VOM2.6: Increase range by up to 400%
- VOM2.6-90: Beam deflection by 90°



OLK 71: Easy to assemble

Top-hat rail included in scope of delivery



Attachment optics for light spot focusing with diffuse reflective sensors

- VOM3: Diameters of 0.5 mm at 8 mm distance
- VOM3: Diameters of 0.7 mm at 10 mm distance



Quickly find the correct length

Included in scope of delivery with SM2 for fiber-optics with customizable length

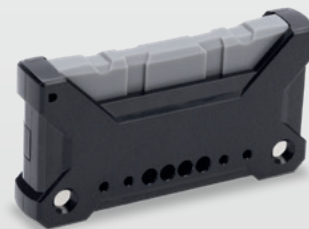

O-Z-REF REFLECTORS & REFLECTIVE FOILS

di-soric offers an extensive range of reflectors and reflection foils for a wide range of application areas. Design options include reflectors for laser, red light and infrared diffuse sensors. Different models with different fastening options and high-temperature-proof designs round out the product range.

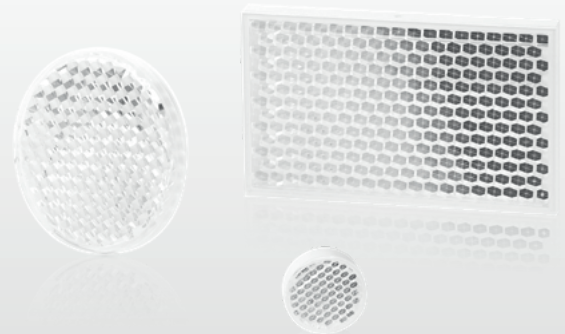

The complete set of accessories can be found at www.di-soric.com

Our extensive selection of accessories is the smart way to supplement and optimize the connection, assembly and function of our sensors, image processing solutions, identification systems and illumination products.



UNIVERSAL ACCESSORIES

CONNECTION TECHNOLOGY

In the area of connection technology, a wide variety of electrical contacts for custom industrial-suited assembly are available.



SIGNAL PREPARATION

Logic distributors can link two sensors with one another (e.g. AND/OR function). Function adapters change switching signals (e.g. Npn, pnp, inversion, pulse stretching), counter modules, counting, switching signals.



UNIVERSAL FASTENING TECHNOLOGY

di-soric offers tailored bracket and fastening systems for all of its sensors, image processing systems, identification systems and lighting.

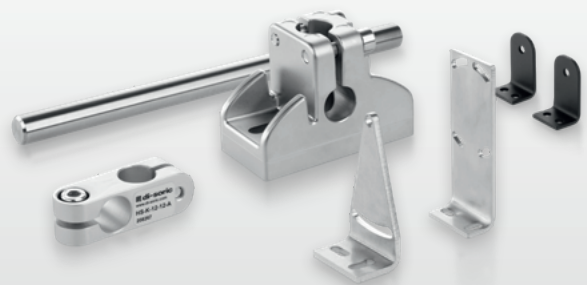

CONFIGURATION AND TESTING DEVICES

Configuration and testing devices facilitate function tests of sensors. IOL Master and IOL Portable enable the display of measured values as well as the diagnoses and the configuration of IO-Link-capable sensors without additional control. The sensor tester is suited for npn and pnp sensors.



IOL MASTER
Operation on PC via USB



IOL PORTABLE
Handheld operation without PC



SENSOR TESTER
ST 7PNG

SOLUTIONS. CLEVER. PRACTICAL.

di-soric Headquarters

Germany: di-soric GmbH & Co. KG | Steinbeisstrasse 6 | 73660 Urbach
Phone +49 71 81 98 79-0 | Fax +49 71 81 98 79-179 | info@di-soric.com

di-soric Subsidiaries

Austria: di-soric GmbH & Co. KG | Phone +43 7228 72 366 | info.at@di-soric.com

France: di-soric SAS | Phone +33 476 61 65 90 | info.fr@di-soric.com

Singapore: di-soric Pte. Ltd. | Phone +65 6694 7866 | info.sg@di-soric.com

Switzerland: di-soric SNT AG | Phone +41 44 817 29 22 | info.ch@di-soric.com

The Netherlands: di-soric B.V. | Phone +31 413 33 13 91 | info.nl@di-soric.com

For further information visit www.di-soric.com/international

www.di-soric.com